

SERGE Dual

Extended ADSR 2017

The Serge Dual Extended ADSR module contains 2 identical Extended ADSR sections, each consisting of a main pcb and a panel pcb:

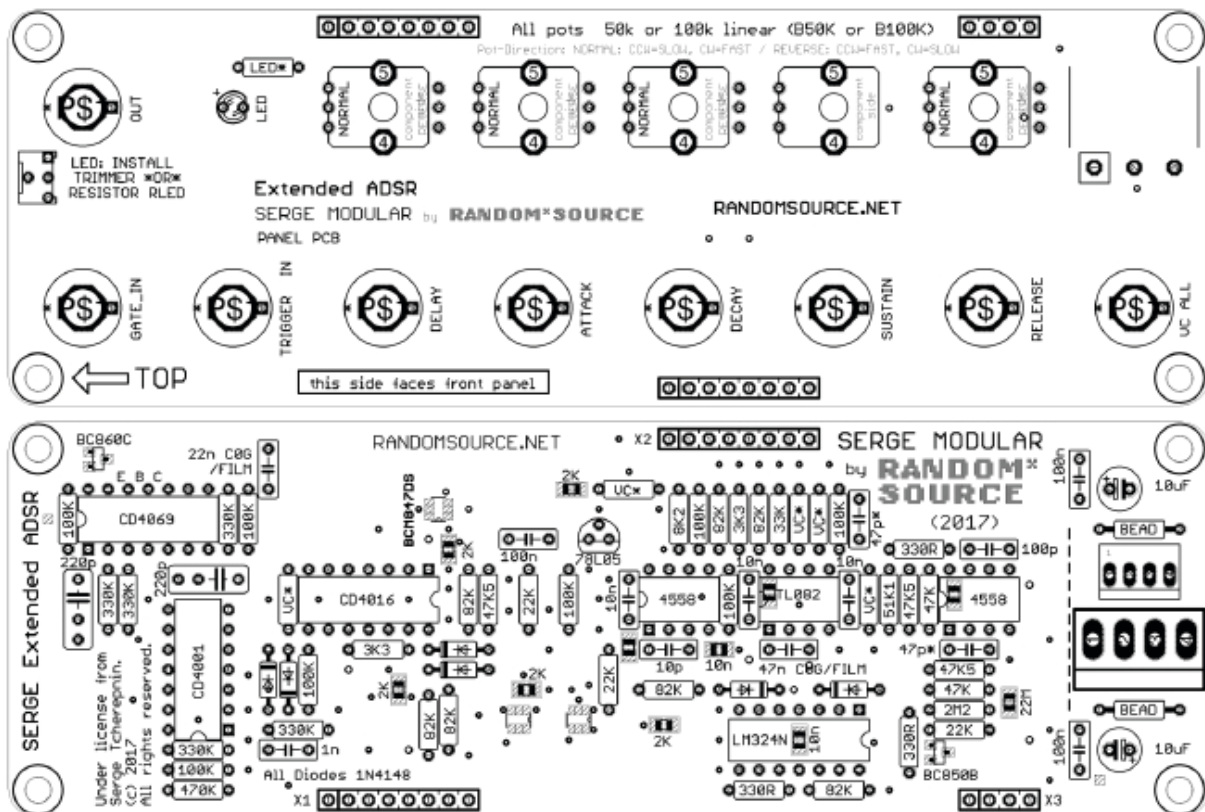

Please note:

- Orientation of the main pcb: **power header is at the bottom** (when looking at the module up-right, e.g. in a rack). Board is designed to be powered by a +/-12V stabilized PSU.
- **All transistors and some SMT part are already reflow-soldered in. Don't install any transistors!**
- Spacing of the resistor pads is fairly narrow. It is recommended to bend the resistor legs right at the body of the resistor and then insert the resistor with the bent legs - it should then fit easily.
- There is a **confusing / incorrect LED + label on the bottom of the pcb - ignore that!** The **correct LED orientation is shown on the pic above** (+ means long leg).
- LED: Install either a trimpot ("LED") or a resistor (RLED) to determine the brightness of the LED - not both. Low current LED is recommended plus a **trimpot of 2k or 5k**. If you use ultra-bright LEDs, a larger value trimmer might make sense.

Bill of Materials (for 1 Ext ADSR - double for the Dual module)

Resistors (1%)

2 10R F1, F2
 1 >= 100R RLED
 (up to 1k)
 2 330R
 2 3K3
 1 8K2
 3 22K
 1 33K
 2 47K
 3 47K5
 1 51K1
 7 82K
 8 100K
 5 330K
 1 470K
 1 2M2
 5 VC*

alt: FERRIT BEAD

Minimum resistance for the LED,
determines maximum brightness

Controls the CV behavior - see text. Original value is

110K for a 1V/Oct response (5V = 5 octaves, 1:32).

For increased VC response use:

90k9 for 6 octaves (1:64)

78k7 for 7 octaves (1:128)

68k1 for 8 octaves (1:256)

61k1 for 9 octaves (1:512)

54k9 for 10 octaves (1:1024)

1 2K or more TR-LED

Trimpot (Bourns 3362P or anything that matches the
footprint) to adjust the LED brightness. Pick value
depending on LED (see text).

Capacitors

1 10p
 2 47p*
 1 100p
 2 220p
 1 1n
 1 22n
 1 47n
 3 100n
 2 10uF

COG/NPO

*only if needed

COG/NPO (or Styroflex...)

COG/NPO (or Styroflex...)

COG/NPO (or Styroflex...)

COG/NPO, Film (or Styroflex...)

COG/NPO, Film

Decoupling caps (X7R, COG/NPO, film ...)

Electrolytic

ICs

1	CD4001BE	or MC14001B, HEF4001B
1	CD4016BE	or MC14016B, HEF4016B
1	CD4069	or MC14069, HEF4069UB
1	78L05	Positive VOLTAGE REGULATOR
1	LM324N	
2	4558	
1	TL082	or OPA2134
6	1N4148	

Misc

1	MTA-156	MTA-156 power connector
2	SIL header 8pol	8-pin connector, links main pcb to component pcb
1	SIL header 4pol	6-pin connector, links main pcb to component pcb
3	DIP-8 sockets	
4	DIP-14 sockets	
1	Banana Jack	Gate In (red) Emerson-Johnson Mouser: 530-108-0902-1 (red) or Thonk
1	Banana Jacks	Trigger In (yellow or gray or ...) Emerson-Johnson Thonk / Mouser: 530-108-0913-1 (gray)
7	Banana Jacks	CV / unipolar (blue or white) Emerson-Johnson Thonk / Mouser: 530-108-0910-1 (blue), 530-108-0901-1 (white)
1	LED 5mm	low current 2mA recommended pick color to suit LED lens
1	LED lens 5mm	VCC, Mouser 593-3000R (red), 593-3000A (amber) ...
1	SPDT switch	(ON - OFF - ON) NKK M2013SS1W01 (no cap) or NKK M2013SS1W01-BE (yellow cap)
5	Potentionmeter 50k or 100k	linear (B50K or B100K) Alpha 9mm vertical pcb mount available from Thonk, Tayda

Building

This is simply a suggestion - you might find a different workflow more practical:

1. Mount the Banana jacks, the LED lens and the switch onto the front panel. If you use a retention ring for the LED lens, attach the ring to the lens.
2. Mount the pots onto the component pcb. Pots should sit on the printed side - this side faces the front panel. Don't solder them in yet. Stick the LED into the component pcb - the long leg must be at the + side.
3. Carefully mount component pcb (with the pots and LED inserted) onto the front panel. First slide / push the LED into the LED lens - all the way, this may take a bit of force. You may then have to wiggle each pot a bit to get the pots through. Make sure the threads of the pots go through completely and the pots sit right at the front panel. You can even screw the pots to the panel to make sure of that, but you have to unscrew them again later (for Step 5).
4. Once everything is nicely in place, especially the LED sitting inside (and not on top) of the LED lens, solder the LED and the pots onto the component pcb (while the front panel is attached). **DO NOT SOLDER THE BANANA JACKS YET!**
5. Remove the component pcb again. Solder short pieces of (stiff) wire - about 10mm long - into the pads for the switch. These should stick up in the air on the printed side (same direction as the pots) and should only go through the pcb as much as required to solder them in (i.e. should not stick out much on the other side).
6. Stuff the main board, beginning with the resistors, then caps etc.
7. Main pcb and component pcb are to be connected through precision DIP socket and pins. It is recommended to use the pins on the main pcb (facing down, soldered from above) and the pin sockets on the component pcb (standing up, soldered from the front panel side). Break or cut off the pieces you need and stick them together so that main pcb and component pcb form a nice sandwich (don't solder yet). Check that you didn't leave out any pins / holes and that the sockets are all on the same side (component pcb). Solder all the pins in while keeping the sandwich together - this avoids any misalignments.
8. Carefully separate the sandwich - if you used precision sockets, this may not be too easy - they stick together nicely (giving a good connection).
9. Mount the component pcb onto the front panel again and screw on the pots from the front side.
10. Make sure everything is in place.

11. Solder the switch in by soldering the air-wires onto the corresponding contacts:

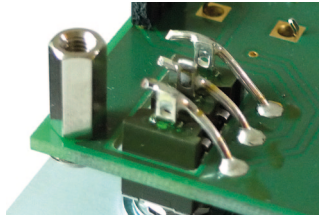

12. Solder the banana jacks in. You can either solder them directly to the surrounding vias (the ring around) or - which makes removing easier should you ever need to do that - by inserting a stiff (bare) wire into the little hole (via) and solder that wire to the top of the banana jack:

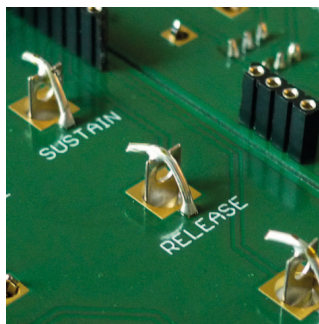

13. Attach any screws / spacers if desired and mount the main pcb onto the component pcb.
14. Connect a power cord supplying +12V, GND, GND, -12V to the MTA-header on the main board and you should be ready to go :-)

Calibration

Module does not require any calibration. Adjust LED brightness according to taste.

Tips

The Extended ADSR can be (ab)used at lower audio rates as kind of a wave shaper.

Should find yourself in a situation where the module seems to do nothing when a Gate or Trigger signal is applied, check the position of the pots and try turning all pots (except SUSTAIN) towards or to the max (CW = fast), long delay times etc. can bring the output to a static level, making the module appear dead.

(Version 25. September 2017, 10:14 PM)

SERGE Modular by Random*Source. Module and circuit under license from Serge Tcherepnin. All rights reserved.