

SERGE

Wave Multipliers

(VCM) for Eurorack

The legendary Serge Wave Multipliers (VCM) are a module - or rather 3 modules - designed to dynamically add new harmonically-related overtones to an input waveform. According to the 1982 catalogue, they “alter the timbre in exciting new ways, producing interesting alternative forms of signal processing which are unique in the Serge Modular Music System. Since there are three entirely separate and different types of Wave Multipliers in this module, an enormously varied palette of new effects can be synthesized.”

The **top section** offers two different modes, selected by a switch. In the “HI” position, the module functions to “square-up” an incoming signal, with a rounded flattening of the signal peaks, somewhat similar to overdriving a tube amplifier (with voltage control!). In “LO” mode, the module is a linear gain controlled VCA. This is useful for various functions such as amplitude modulation and for gating signals into the other sections.



The **middle section** generates a sweep of the odd harmonics (1, 3, 5, 7, 9, 11 and 13th) when a sine wave is applied to its input and the FOLD knob is turned up or a control voltage is swept from low to high. This effect is similar to overblowing a wind pipe closed at one end. A second input is included to allow two signals to be mixed before processing. This module can be used to explore timbral areas beyond the range of ring modulation.

The **bottom Wave Multiplier** performs non-linear wavehaping known as full-wave rectification, but with sophisticated level-compensating conditioning as well. The circuit uses three full-wave rectifier sections linked in a very refined controllable format. Sweeping the VC input over its range will produce a smooth timbral transi-

tion using the even harmonics (second, fourth, and eighth). Many other partials are present in this basic sound, however, and the sonorities are very rich and varied. The white output is a “squared up” version of the black one, resembling an harmonically enhanced pulse width modulation.

The Random*Source version of the Serge Wave Multipliers for Euro is a licensed and authorized adaptation of the original Serge design, using best parts available today (e.g. Burr-Brown op-amps, COG capacitors up to 220N) for optimum audio performance.

The Random*Source VCM kit consists of a front panel, a main pcb that already contains most of the parts in surface-mount technology (SMT) and a component pcb serving as an interface to the front panel.

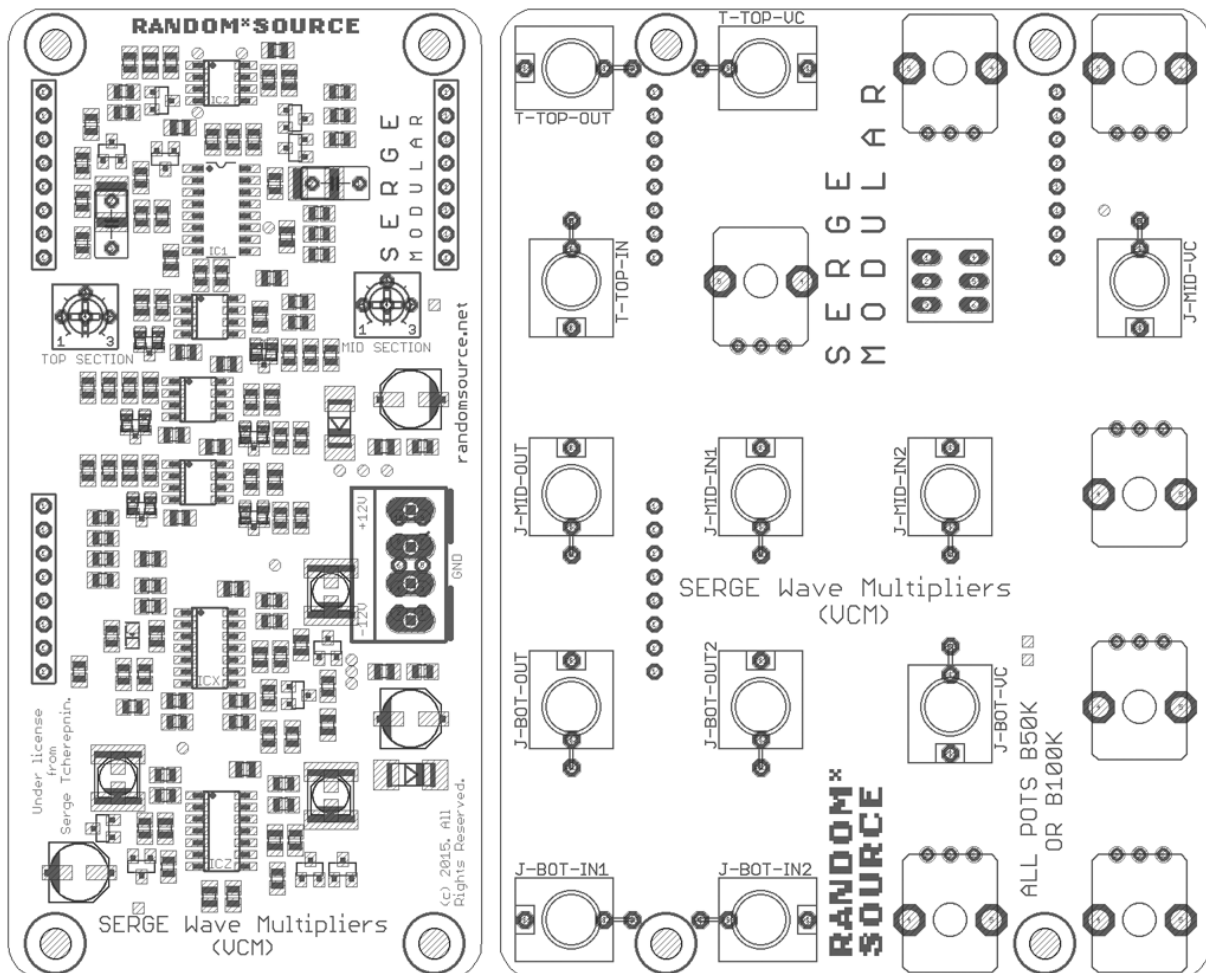

Please note:

- The front panel is color (screen) printed. **Do not use strong cleaning liquids, solvents, acid, ethanol, detergents or similar to clean the front panel** as that could solve/harm the paint. A damp cloth should be sufficient if you need to clean it.
- **Use antistatic precaution** when handling the main pcb - don't touch the SMD parts with your hands.
- Only very few parts have to be soldered in: 2 trimpots, pin strip headers to connect the main pcb to the component pcb as well as the power header (see picture above).
- The **main pcb is designed to sit upside-down**, so that all the SMT components are between the two pcbs - that means the **2 trimmers and the power header have to be soldered on the SMT side**.
- Orientation of the main pcb: **power header is on the left** (when looking at the back of the upright module), RED STRIPE (-12V) is marked on the pcb.

Bill of Materials

Trimmers

2	100k	Top section, Mid section	Trimpot (Bourns 3362P, Vishay T73YP104KT20 or anything that matches the footprint). See calibration info below.
---	------	-----------------------------	---

Misc

1	Switch DPDT	HI / LO	Sub-Miniature Switch ON - ON, e.g. Mountain Switch (Mouser: 108-0043-EVX)
1	Euro Power header		MTA-100 power connector, Reichelt: WSL 10G
3	SIL header 8pol		pin connectors/headers, linking main pcb to component pcb - using precision strips allows to break off pieces as needed
12	Thonkiconn Jacks		3.5mm Jack Sockets (PJ301M-12) from Thonk
7	Potionmeter	linear (B50K or B100K)	Alpha 9mm vertical pcb mount
	50k (or 100k)		available from Thonk, Tayda

Power Connector

The module is designed to be powered using a standard Eurorack 10-pin DIP header (pinout +12V / GND / GND / GND / -12V with the **red stripe on the cable indicating the -12V side**).

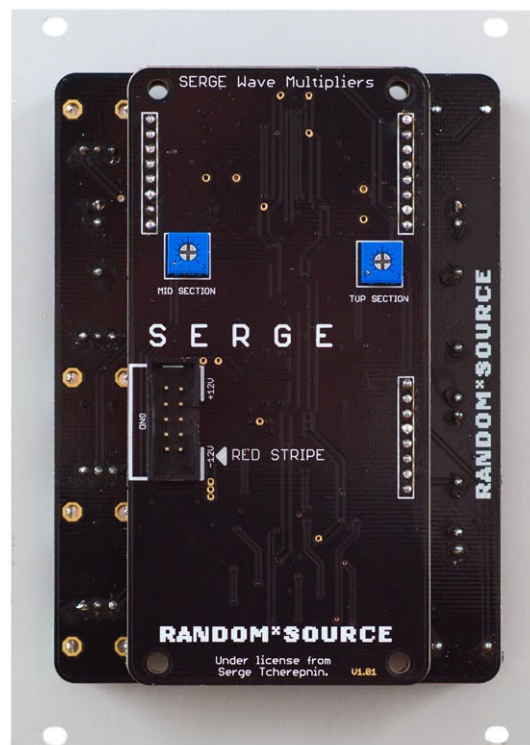
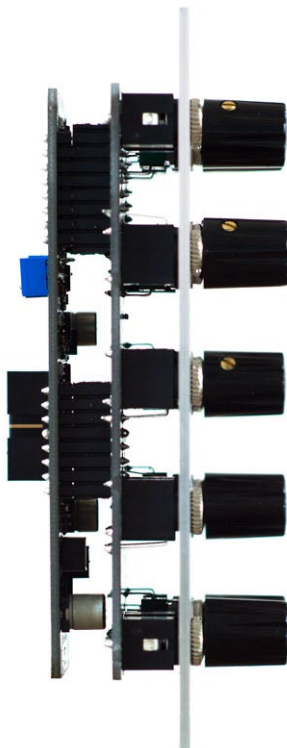

Building

1. Use a side-cutter to separate main pcb and component pcb.
2. Main pcb and component pcb are to be connected through precision DIP socket and pins. It is recommended to use the pins on the main pcb (facing down, soldered from above) and the pin sockets on the component pcb (standing up, soldered from the front panel side). Break or cut off the pieces you need and stick them together so that main pcb and component pcb form a nice sandwich (don't solder yet). Check that you didn't leave out any pins / holes and that the sockets are all on the same side (component pcb). **The SMT side of the main pcb has to face the component pcb (i.e. be inside the sandwich)**. Solder all the pins in while keeping the sandwich together - this avoids any misalignments.
3. **Carefully** separate the sandwich - if you used precision sockets, this may not be too easy - they stick together nicely (giving a good connection).
4. Mount the Thonkiconn jacks, the pots and the switch onto the component pcb. Pots should sit on the side facing the front panel (as marked on the board). Don't solder them in yet.
5. Attach any screws / spacers if desired to the component pcb (this gets more difficult once the component pcb is connected to the front panel).
6. Carefully mount the component pcb (with the pots etc. inserted) onto the front panel. You may then have to wiggle each pot a bit to get the pots through. Make sure the threads of the pots go through completely and the pots sit right at the front panel. Screw the jacks, pots and switches to the front panel to make sure of that.
7. Once everything is nicely in place, solder the pots, jacks and switch onto the component pcb (while the front panel is attached).
8. Solder the trimpots, and the power header onto the main pcb - **make sure they sit on the right side (not where the SMT parts are!)**.
9. Connect a power cord supplying +12V, GND, GND, -12V to the power-header on the main board and double check the direction of the power header before you turn power on. You should be ready to go now :-)

Calibration

Top and middle section each have a trimmer to adjust CV rejection. Calibration is easy:

1. Feed an audio signal into the CV input of that section. Make sure the attenuator is at maximum position (CW) to let the signal through.
2. Using an oscilloscope or your ears, adjust the trimmer so that the output of that section shows the least amount of that input signal.

Power Consumption

Power consumption: $\leq 45\text{mA}$ @ +12V and $\leq 40\text{mA}$ @ -12V

Module width: 18HP, depth: < 35 mm

(Version 16 December 2015)

SERGE Modular by Random*Source. Module and circuit under license from Serge Tcherepnin. All rights reserved.